

Accepted Manuscript

Novel Mutations in the *GPIHBP1* Gene Identified in Two Patients with Recurrent Acute Pancreatitis

María José Ariza, Pedro Luis Martínez-Hernández, Daiana Ibarretxe, Claudio Rabacchi, José Rioja, Cristina Grande-Aragón, Nuria Plana, Patrizia Tarugi, Gunilla Olivecrona, Sebastiano Calandra, Pedro Valdivielso

PII: S1933-2874(15)00385-2

DOI: [10.1016/j.jacl.2015.09.007](https://doi.org/10.1016/j.jacl.2015.09.007)

Reference: JACL 813

To appear in: *Journal of Clinical Lipidology*

Received Date: 3 June 2015

Revised Date: 9 September 2015

Accepted Date: 16 September 2015

Please cite this article as: Ariza MJ, Martínez-Hernández PL, Ibarretxe D, Rabacchi C, Rioja J, Grande-Aragón C, Plana N, Tarugi P, Olivecrona G, Calandra S, Valdivielso P, Novel Mutations in the *GPIHBP1* Gene Identified in Two Patients with Recurrent Acute Pancreatitis, *Journal of Clinical Lipidology* (2015), doi: 10.1016/j.jacl.2015.09.007.

This is a PDF file of an unedited manuscript that has been accepted for publication. As a service to our customers we are providing this early version of the manuscript. The manuscript will undergo copyediting, typesetting, and review of the resulting proof before it is published in its final form. Please note that during the production process errors may be discovered which could affect the content, and all legal disclaimers that apply to the journal pertain.



1 **Title page**

2

3 **NOVEL MUTATIONS IN THE *GPIHBP1* GENE IDENTIFIED IN TWO PATIENTS WITH**
4 **RECURRENT ACUTE PANCREATITIS**

5

6 ^aMaría José Ariza, ^bPedro Luis Martínez-Hernández,; ^cDaiana Ibarretxe, ^dClaudio Rabacchi,
7 ^aJosé Rioja, ^eCristina Grande-Aragón, ^cNuria Plana, ^dPatrizia Tarugi, ^fGunilla Olivecrona,
8 ^gSebastiano Calandra, ^{a,h}Pedro Valdivielso

9

10 ^aDepartment of Medicine and Dermatology. Lipids and Atherosclerosis Laboratory. CIMES,
11 University of Málaga, Málaga, Spain.

12

13 ^bDepartment of Internal Medicine. La Paz University Hospital, Madrid, Spain

14

15 ^cVascular Medicine and Metabolism Unit, Research Unit on Lipids and Atherosclerosis, Sant
16 Joan University Hospital, Universitat Rovira i Virgili, IISPV, Spanish Biomedical Research
17 Centre in Diabetes and Associated Metabolic Disorders (CIBERDEM), Reus, Spain.

18

19 ^dDepartment of Life Sciences, University of Modena & Reggio Emilia, Modena, Italy

20

21 ^eDepartment of Biochemistry, La Paz University Hospital, Madrid, Spain.

22

23 ^fDepartment of Medical Biosciences/Physiological Chemistry, Umeå University, Umeå, Sweden

24

25 ^gDepartment of Biomedical, Metabolic and Neural Sciences, University of Modena & Reggio
26 Emilia. Modena, Italy

27

28 ^hInternal Medicine Unit, Virgen de la Victoria University Hospital, Málaga, Spain.

29

30

31 **Disclosures**32 The authors have disclosed the financial support for carrying out the work and after reading the
33 journal's policy declare that there is no conflicts of interest associated to this article.

34

35 **E-mail address of each author**

36

37 María José Ariza mariza@uma.es38 Pedro-Luis Martínez Henández pedroluis.martinez@salud.madrid.org39 Daiana Ibarretxe daianaig@hotmail.com40 Claudio Rabacchi claudio_rabacchi@hotmail.it41 José Rioja jose.rioja@uma.es42 Cristina Grande-Aragón cgrande.hulp@salud.madrid.org43 Nuria Plana nplana@grupsagessa.cat44 Patrizia Tarugi tarugi@unimore.it45 Gunilla Olivecrona gunilla.olivecrona@medbio.umu.se46 Sebastiano Calandra sebcas@unimore.it47 Pedro Valdivielso valdivielso@uma.es

48

49

50

51 **Corresponding author:**

52

53 María José Ariza. mariza@uma.es

54 Laboratorio de Lípidos y Arteriosclerosis.

55 Centro de Investigaciones Médico-Sanitarias (CIMES).

56 C/ Marqués de Beccaria nº 3.

57 Campus de Teatinos. Universidad de Málaga.

58 29010 Málaga. Spain

59 Tel.: +34 952137277; fax: +34 952137270

60

61 **Word count:** 2241

62

ACCEPTED MANUSCRIPT

63 **ABSTRACT**

64

65 **Background:** Glycosylphosphatidylinositol-anchored high-density lipoprotein-binding protein 1
66 (GPIHBP1) has been demonstrated to be essential for the *in vivo* function of Lipoprotein Lipase
67 (LPL), the major triglyceride (TG) hydrolyzing enzyme involved in the intravascular lipolysis of
68 TG-rich lipoproteins. Recently loss of function mutations of *GPIHBP1* have been reported as the
69 cause of Type I hyperlipoproteinemia in several patients.

70 **Methods:** Two unrelated patients were referred to our Lipid Units because of a severe
71 hypertriglyceridemia and recurrent pancreatitis. We measured LPL activity in post-heparin
72 plasma and serum ApoCII and sequenced *LPL*, *APOC2* and *GPIHBP1*.

73 **Results:** The two patients exhibited very low LPL activity not associated with mutations in *LPL*
74 gene or with ApoCII deficiency. The sequence of *GPIHBP1* revealed two novel point mutations.
75 One patient (Proband 1) was found to be homozygous for a C>A transversion in exon 2
76 resulting in the conversion of threonine to lysine at position 80 (p.Thr80Lys). The other patient
77 (Proband 2) was found to be homozygous for a G>T transversion in the third base of the ATG
78 translation initiation codon in exon 1, resulting in the conversion of methionine to isoleucine
79 (p.Met1Ile).

80 **Conclusion:** In conclusion, we have identified two novel *GPIHBP1* missense mutations in two
81 unrelated patients as the cause of their severe hypertriglyceridemia.

82

83

84 **Keywords:** Glycosylphosphatidylinositol-anchored high-density lipoprotein-binding protein 1
85 (GPIHBP1), severe hypertriglyceridemia, recurrent pancreatitis, lipoprotein lipase activity.

86

87 1. Introduction

88 Type I and V hyperlipoproteinemia are characterized by high concentrations of chylomicrons in
89 the fasting state, a condition which increases the risk of acute pancreatitis¹. Monogenic forms of
90 familial hyperchylomicronemia are due to defects in the lipolytic cascade of triglyceride (TG)
91 rich lipoproteins that may result from mutations in at least five different genes: *LPL*, encoding
92 the enzyme lipoprotein lipase (LPL; OMIM #238600) and involved in the majority of cases of
93 chylomicronemia^{2,3}; *APOC2*, encoding the Apolipoprotein CII, the activator of LPL (ApoCII;
94 OMIM #207750)⁴; *APOA5*, encoding the Apolipoprotein AV, also an activator of LPL (ApoAV;
95 OMIM #144650)⁵; *LMF1*, encoding the Lipase Maturation Factor 1, a tissue factor which allows
96 the secretion of functional LPL and Hepatic Lipase (HL; OMIM #611761)⁶ and *GPIHBP1*,
97 encoding the Glycosylphosphatidylinositol-anchored high-density lipoprotein-binding protein 1,
98 the molecular platform for LPL on the endothelial surface of capillaries, (*GPIHBP1*; OMIM
99 #612757)^{7,8}.

100

101 *GPIHBP1* is a 184 aa endothelial cell protein which acts as a transporter for LPL across the
102 endothelial cells to the capillary lumen and appears to be the main binding site for LPL on the
103 endothelial surface⁹. *GPIHBP1* belongs to the Ly6 protein family^{10,11}, so called because of a
104 lymphocyte antigen 6 domain that contains 10 cysteine residues forming disulfide bonds and
105 creating a characteristic three-finger structural motif. The Ly6 domain is crucial because it is
106 involved in the binding to LPL and allows the interactions of LPL with ApoCII, ApoAV and TG-
107 rich lipoproteins on the endothelial surface.

108

109 Most missense mutations found in *GPIHBP1* causing type I hyperlipoproteinemia are located in
110 the Ly6 domain and many of them affect a cysteine residue¹²⁻¹⁴. Interestingly, it has been
111 recently described that many amino acid substitutions in this domain lead to the formation of
112 disulfide-linked dimers and multimers. The formation of multimers explains the loss of function
113 of *GPIHBP1* as *GPIHBP1* monomers are capable of binding LPL¹⁵. In addition, a mutation
114 affecting the C-terminal domain has been shown to impair *GPIHBP1* trafficking to the
115 endothelial cell surface¹⁶. Finally, nonsense/frameshift mutations and large exon deletions in
116 this gene have also been described in some patients with Type I hyperlipoproteinemia¹⁷⁻¹⁹.

117

118 In this study we report two novel *GPIHBP1* missense mutations identified in two unrelated
119 patients as the cause of their severe hypertriglyceridemia.

120

121 2. Materials and methods

122 2.1. Subjects

123 Clinical, demographic, anthropometric and laboratory data were retrieved from clinical records
124 of two patients who attended the outpatient clinic at Hospital La Paz (Madrid) and Hospital de
125 Reus (Tarragona) respectively. Informed written consent has been obtained from the patients
126 and their relatives participating to the study. The study was approved by the Ethic Committee of
127 the participating institutions.

128 2.2. Plasma lipid analyses

129 Serum samples were obtained after an overnight fasting. Cholesterol and triglycerides were
130 determined by automated end-point enzymatic methods. Serum ApoCII was quantified by
131 immunoturbidimetry in a Mindray Bs-380 Clinical Autoanalyzer (Mindray. zhensheng. China)
132 using commercial assays (Spinreact. Barcelona, Spain).

133

134 2.3. LPL activity assay

135 A blood sample was drawn from each proband 15 minutes after the intravenous injection of
136 sodium heparin (100 units/kg) in order to measure post-heparin plasma LPL activity. LPL
137 activity was measured using a lipid emulsion containing triolein [9,10-3H(N)] (Perkin Elmer
138 NET431) as a substrate according to Olivecrona *et al.*²⁰.

139 2.4. Genetic analyses

140 Genomic DNA was isolated from frozen whole blood in EDTA using an EZ1 BioRobot®
141 (QIAGEN, Hilden, Germany) with the appropriate reagents. The genotyping of common
142 polymorphisms in *APOE* (rs429358, rs7412) and *APOA5* (rs3135506, rs662799) was performed
143 using TaqMan assays in a real-time thermal cycler CFX96™ (BioRad, California, USA), the iQ™
144 Supermix and the allele discrimination mode of the CFX96™ software, as described
145 previously²¹.

146 The sequencing of the *LPL*, *APOC2* and *GPIHBP1* exons and splice junctions was carried out
147 as previously described¹⁹. The mutations were designated according to the Human Genome
148 Variation Society, 2012 version (<http://www.hgvs.org/mutnomen/recs-DNA.html>). *GPIHBP1*
149 protein sequence variants were designated according to [http://www.hgvs.org/mutnomen/recs-](http://www.hgvs.org/mutnomen/recs-prot.html)
150 [prot.html](http://www.hgvs.org/mutnomen/recs-prot.html).

151 The biological impact of the novel missense mutations found in the probands were tested *in*
152 *silico* with two algorithms: SIFT (Sort Intolerant From Tolerant). sift.jcvi.org and Polyphen 2;
153 genetics.bwh.harvard.edu/pph2/.

154 The two novel *GPIHBP1* mutations found in the probands were screened in 200
155 normolipidaemic controls using two independent High Resolution Melting (HRM) assays.

156 3. Results

157 Proband 1, a 39-year-old Pakistani male, was referred to the Lipid Unit of the University
158 Hospital San Joan (Reus, Spain) when he presented with the fifth episode of acute pancreatitis.
159 After that episode he developed insulin dependent diabetes. This patient had had the first
160 episode of pancreatitis at the age of 23. The highest recorded TG level was 4489 mg/dL. During
161 the last year, the patient has been treated with a low-fat diet supplemented with medium chain
162 triglycerides (SHS, Nutricia) 30 mL/day, plus atorvastatin 10 mg, fenofibrate 145 mg and 3 g of
163 omega-3 fatty acids. This treatment however, did not improve his clinical conditions nor did it
164 reduce plasma TG levels below 1000 mg/dL. He did not show eruptive xanthomas,
165 hepatosplenomegaly or lipemia retinalis. No family members were available for study although
166 we could confirm that his parent were first cousins and he has four brothers (Figure 1).

167 Proband 2 is a 25-year-old female from Ecuador born from consanguineous parents (first
168 cousins). She attended the hospital La Paz (Madrid, Spain) for follow up when she started
169 treatment with low-fat diet supplemented with medium-chain triglycerides (Nutrición Médica,
170 Madrid, Spain) 20 mL/day, plus fenofibrate 145 mg, 2 g of omega-3 fatty acids and 600 mg of
171 crystalline niacin. No beneficial effects were obtained in clinical or biochemical terms. Since the
172 age of 15 she had had 12 episodes of acute pancreatitis. The highest recorded TG level was
173 3820 mg/dL. The lowest TG level reported was 343 mg/dL when she managed to follow a strict
174 vegetarian diet and do sport every day. Proband 2 is the eldest of four healthy siblings which
175 were available for the study together with their mother (Figure 1). Eruptive xanthomas,
176 hepatosplenomegaly or lipemia retinalis were not observed in this patient. There was no known
177 family history of pancreatitis.

178 The biochemical and genetic data are shown in Table 1. At the time of the molecular diagnosis
179 both probands had triglycerides levels above 1000 mg/dL. Both patients exhibited very low
180 levels of post-heparin plasma LPL activity compared with hypertriglyceridaemic patients without
181 LPL deficiency (92 mU/mL \pm 44 mU/mL)²². Plasma ApoCII level was in the range found in our
182 series of patients with severe hypertriglyceridemia²³.

183 In both probands the sequence of the *LPL* as well as the sequence of the *APOC2* gene did not
184 reveal the presence of rare variants nor polymorphisms that could account for the very low LPL
185 activity (Supplementary table S1). The sequencing of *GPIHBP1* revealed two novel point
186 mutations (Figure 2). Proband 1 was found to be homozygous for a C > A transversion in exon
187 2 resulting in the conversion of threonine to lysine at position 80 (p.Thr80Lys, p.T80K). Proband
188 2 was found to be homozygous for a G>T transversion in the third base of the ATG translation
189 initiation codon in exon 1 resulting in the conversion of methionine to isoleucine (p.Met1Ile,
190 p.M1I).

191 According to *in silico* analysis (PolyPhen-2) the Thr80Lys mutation was predicted to be possibly
192 damaging and the Met1Ile probably damaging. According to SIFT algorithm both mutations
193 were predicted to be damaging.

194 The sequencing of the first exon of *GPIHBP1* in the relatives of Proband 2 revealed that the
195 mother (B.I-2, Figure 1) and the youngest brother (B.II-4) of the proband were heterozygous
196 carriers of the mutation (Table 1).

197 None of the two *GPIHBP1* mutations was found in the public data base from the National
198 Center of Biotechnology, (<http://www.ncbi.nlm.nih.gov/>); from the Human Gene Mutation
199 Database (<http://www.hgmd.cf.ac.uk/ac/index.php>) nor from the 1000 Genomes Catalog of
200 Human Genetic Variation (<http://browser.1000genomes.org/index.html>). In addition, no
201 carriers of the mutations were identified in a group of normolipidaemic Spanish workers²¹. A
202 summary of the mutations in *GPIHBP1* found in severe hypertriglyceridaemic patients so far is
203 displayed in Table 2.

204 Additionally to the *GPIHBP1* mutation, Proband 2 was homozygous for the rare allele of the
205 common SNP in *APOA5*: rs3135506 (p.Ser19Trp), while her mother (B.I-2) was heterozygous
206 and one of her brothers (B.II-2) was homozygous for this SNP (Table 1). Moreover, the
207 youngest brother (B.II-4) was heterozygous not only for p.Ser19Trp variant but also for another
208 SNP (rs662799; c.-1131C>T) in the *APOA5* gene. In all subjects the *APOE* genotype was ϵ 3 ϵ 3.

209 4. Discussion

210 *GPIHBP1* has been demonstrated to be an essential factor for intravascular lipolysis of TG-rich
211 lipoproteins mediated by LPL². Recently different *GPIHBP1* missense mutations have been
212 found in patients with Type I hypertriglyceridaemia. In the present study we describe two novel
213 rare variants of *GPIHBP1* gene found in homozygous state in two patients with severe
214 hypertriglyceridemia associated with extremely low LPL activity in post-heparin plasma.

215 The clinical features of our patients were similar to those of other adult patients with *GPIHBP1*
216 mutations reported so far (Table 2). Our patients showed persistently elevated plasma TG that
217 did not respond to lipid lowering treatment and had partial response to diet^{24,12-14,16,25-27}. Most
218 patients with severe hypertriglyceridemia carrying mutations in *GPIHBP1* suffer from
219 pancreatitis bouts (62% of cases described in Table 2 with these data available), including very
220 young children^{16,28,29} and, like in our probands, in some patients pancreatitis is reported to be
221 recurrent^{13,16,17,24}. On the other hand, we haven't observed in our patients other associated
222 symptoms such as eruptive xanthomas, lipemia retinalis or hepatosplenomegaly (45% of cases
223 in Table 2). Finally, CHD is reported just in the two oldest patients described in Table 2^{13,24}.

224 Proband 1 (Table 1) is homozygous for a non-conservative amino acid substitution (p.Thr80Lys)
225 located in Finger 1 of the Ly6 domain of the GPIHBP1 protein. This is the first naturally
226 occurring mutation in Finger 1 that does not affect a cysteine residue. The threonine residue at
227 position 80 belongs to a N-glycosylation consensus sequence and is close to the cysteine
228 residue at position 83. The substitution of an uncharged polar amino acid (threonine MW
229 119.13) with a positively charged polar amino acid that is larger in size (lysine MW146.19) is
230 expected to disrupt the sequence of Finger 1 domain and to be deleterious. This prediction is
231 supported by *in vitro* mutagenesis studies which demonstrated that p.Thr80Lys GPIHBP1
232 mutant, when expressed in CHOK1 cells, showed a reduced expression on the cell surface
233 (suggesting an impaired intracellular transport) as well as a markedly reduced binding of LPL (>
234 90% reduction)³⁰. In view of these findings we can reasonably conclude that p.Thr80Lys
235 substitution is the cause of LPL deficiency in our patient.

236 The ATG (AUG) to ATT (AUU) conversion (leading to p.Met1Ile substitution) in the translation
237 initiation codon found in Proband 2 is the first mutation affecting the *GPIHBP1* translation
238 initiation codon described so far. Mutations affecting the translation initiation codon in human
239 genes are relatively uncommon as compared to other exonic mutations and usually are
240 considered deleterious. Interestingly, this type of mutation has been reported in other genes
241 involved in intravascular lipolysis of TG-rich lipoproteins such as *LPL*^{31,32} and *APOC2*³³.

242 The effect of the conversion of the ATG (AUG) initiation codon to ATT (AUU) may have a
243 variable effect on the efficiency of translation. The mutation can result in: i) a complete block of
244 translation initiation with no production of GPIHBP1; ii) a reduced efficiency of translation
245 initiation by the mutant translation initiation codon (with a parallel reduction of the synthesis of
246 Met1Ile mutant GPIHBP1); iii) an activation of one or more alternative translation initiation
247 codons along the mRNA sequence with a variable translation efficiency. The visual inspection of
248 GPIHBP1 mRNA sequence reveals the presence of ATG triplets at 106, 125, 130, 253 and 381
249 nucleotides downstream from the position +1 (corresponding to the Adenine of the canonical
250 ATG). These ATG triplets might be regarded as possible translation initiation sites, if embodied
251 in a nucleotide sequence similar to Kozak consensus initiation sequence [(GCC) GCC -3
252 A/GCC ATG +4 G]³⁴. However, the activation of alternative translation initiation sites at position
253 106, 125 or 130 is out of frame with respect to the canonical ATG initiation site and would lead
254 to the insertion of a premature termination codon (TGA at position 231).

255 Regardless of the possible effect of the ATG->ATT mutation on the translation process,
256 Proband 2 showed a dramatic reduction of LPL activity suggesting either a very low production
257 of the mutant GPIHBP1 carrying the Met1Ile mutation (due to a residual initiation translation
258 efficiency) or the production of a structurally abnormal GPIHBP1 protein devoid of function.

259 As expected, plasma TG levels observed in the heterozygous relatives of proband 2 were in a
260 normal range in agreement with many other cases described in the literature^{16-18,26}. A stringent
261 follow up of these subjects is highly recommended as they (like heterozygotes for *LPL* or
262 *APOA5* gene mutations) may be prone to develop hypertriglyceridemia and be at risk of
263 pancreatitis, when secondary factors such as diabetes, obesity, alcohol abuse or pregnancy
264 should occur². In this context it is especially interesting the case of the youngest brother of
265 proband 2 who has a normal TG level in spite of being not only a carrier of the *GPIHBP1*-
266 Met1Ile mutation but also of two common *APOA5* SNPs known to be associated with
267 hypertriglyceridemia in adults^{21,35} as well as in children^{36,37}.

268 Our results highlight the importance of sequencing the *GPIHBP1* gene in those patients with
269 severe hypertriglyceridemia negative for mutations in *LPL* and *APOC2*. The number of
270 *GPIHBP1* mutations found in these patients has increased during the last few years suggesting
271 that the *GPIHBP1* gene mutations may be more frequent than previously assumed.

272

273 **Authors' contributions**

274 MJA contributed to the study design, participated in the genetic analyses and drafted the
275 manuscript. PLMH, DI, CGA and NP were in charge of the patient's management and carried
276 out the data collection. MJA and CR performed the sequencing of the GPIHBP1 gene and the *in*
277 *vitro* analyses of the mutations. PT and SC participated in the design and coordination of the
278 study and helped to draft the manuscript. JR carried out the plasma lipid analysis and the LPL
279 activity assays. GO contributed to the LPL activity assays and helped to draft the manuscript.
280 PV conceived the study, participated in its coordination and helped to draft the manuscript. All
281 authors read and approved the final version of the manuscript

282 **Acknowledgements**

283 This study was supported by a grant of Emilia-Romagna Region Rare Disease project
284 (E35E09000880002) (S.C. and P.T.) and a grant from the Junta de Andalucía to the CTS 159
285 group of the PAIDI.

286 **References**

- 287 [1] Valdivielso P, Ramirez-Bueno A, Ewald N. Current knowledge of
288 hypertriglyceridemic pancreatitis. *Eur J Intern Med.* 2014;25:689-694.
- 289 [2] Gotoda T, Shirai K, Ohta T, Kobayashi J, Yokoyama S, Oikawa S, Bujo H, Ishibashi S,
290 Arai H, Yamashita S, Harada-Shiba M, Eto M, Hayashi T, Sone H, Suzuki H, Yamada N,
291 Research Committee for Primary Hyperlipidemia, Research on Measures against
292 Intractable Diseases by the Ministry of Health, Labour and Welfare in Japan. Diagnosis
293 and management of type I and type V hyperlipoproteinemia. *J Atheroscler Thromb.*
294 2012;19:1-12.
- 295 [3] Kassner U, Salewsky B, Wuhle-Demuth M, Szijarto IA, Grenkowitz T, Binner P, Marz
296 W, Steinhagen-Thiessen E, Demuth I. Severe hypertriglyceridemia in a patient
297 heterozygous for a lipoprotein lipase gene allele with two novel missense variants. *Eur*
298 *J Hum Genet.* 2015.
- 299 [4] Okubo M, Toromanovic A, Ebara T, Murase T. Apolipoprotein C-II Tuzla: a novel
300 large deletion in APOC2 caused by Alu-Alu homologous recombination in an infant
301 with apolipoprotein C-II deficiency. *Clin Chim Acta.* 2015;438:148-153.
- 302 [5] Pisciotto L, Fresa R, Bellocchio A, Guido V, Priore Oliva C, Calandra S, Bertolini S.
303 Two novel rare variants of APOA5 gene found in subjects with severe
304 hypertriglyceridemia. *Clin Chim Acta.* 2011;412:2194-2198.
- 305 [6] Hosseini M, Ehrhardt N, Weissglas-Volkov D, Lai CM, Mao HZ, Liao JL, Nikkola E,
306 Bensadoun A, Taskinen MR, Doolittle MH, Pajukanta P, Peterfy M. Transgenic
307 expression and genetic variation of Lmf1 affect LPL activity in mice and humans.
308 *Arterioscler Thromb Vasc Biol.* 2012;32:1204-1210.

- 309 [7] Beigneux AP, Davies BS, Gin P, Weinstein MM, Farber E, Qiao X, Peale F, Bunting S,
310 Walzem RL, Wong JS, Blaner WS, Ding ZM, Melford K, Wongsiriroj N, Shu X, de Sauvage
311 F, Ryan RO, Fong LG, Bensadoun A, Young SG. Glycosylphosphatidylinositol-anchored
312 high-density lipoprotein-binding protein 1 plays a critical role in the lipolytic processing
313 of chylomicrons. *Cell Metab.* 2007;5:279-291.
- 314 [8] Young SG, Davies BS, Fong LG, Gin P, Weinstein MM, Bensadoun A, Beigneux AP.
315 GPIHBP1: an endothelial cell molecule important for the lipolytic processing of
316 chylomicrons. *Curr Opin Lipidol.* 2007;18:389-396.
- 317 [9] Adeyo O, Goulbourne CN, Bensadoun A, Beigneux AP, Fong LG, Young SG.
318 Glycosylphosphatidylinositol-anchored high-density lipoprotein-binding protein 1 and
319 the intravascular processing of triglyceride-rich lipoproteins. *J Intern Med.*
320 2012;272:528-540.
- 321 [10] Beigneux AP, Davies BS, Bensadoun A, Fong LG, Young SG. GPIHBP1, a GPI-
322 anchored protein required for the lipolytic processing of triglyceride-rich lipoproteins. *J*
323 *Lipid Res.* 2009;50 Suppl:S57-62.
- 324 [11] Beigneux AP, Weinstein MM, Davies BS, Gin P, Bensadoun A, Fong LG, Young SG.
325 GPIHBP1 and lipolysis: an update. *Curr Opin Lipidol.* 2009;20:211-216.
- 326 [12] Plengpanich W, Young SG, Khovidhunkit W, Bensadoun A, Karnman H, Ploug M,
327 Gardsvoll H, Leung CS, Adeyo O, Larsson M, Muanpetch S, Charoen S, Fong LG,
328 Niramitmahapanya S, Beigneux AP. Multimerization of glycosylphosphatidylinositol-
329 anchored high density lipoprotein-binding protein 1 (GPIHBP1) and familial
330 chylomicronemia from a serine-to-cysteine substitution in GPIHBP1 Ly6 domain. *J Biol*
331 *Chem.* 2014;289:19491-19499.
- 332 [13] Yamamoto H, Onishi M, Miyamoto N, Oki R, Ueda H, Ishigami M, Hiraoka H,
333 Matsuzawa Y, Kihara S. Novel combined GPIHBP1 mutations in a patient with
334 hypertriglyceridemia associated with CAD. *J Atheroscler Thromb.* 2013;20:777-784.
- 335 [14] Surendran RP, Visser ME, Heemelaar S, Wang J, Peter J, Defesche JC, Kuivenhoven
336 JA, Hosseini M, Peterfy M, Kastelein JJ, Johansen CT, Hegele RA, Stroes ES, Dallinga-
337 Thie GM. Mutations in LPL, APOC2, APOA5, GPIHBP1 and LMF1 in patients with severe
338 hypertriglyceridaemia. *J Intern Med.* 2012;272:185-196.
- 339 [15] Beigneux AP, Fong LG, Bensadoun A, Davies BS, Oberer M, Gardsvoll H, Ploug M,
340 Young SG. GPIHBP1 Missense Mutations Often Cause Multimerization of GPIHBP1 and
341 Thereby Prevent Lipoprotein Lipase Binding. *Circ Res.* 2014.
- 342 [16] Charriere S, Peretti N, Bernard S, Di Filippo M, Sassolas A, Merlin M, Delay M,
343 Debard C, Lefai E, Lachaux A, Moulin P, Marçais C. GPIHBP1 C89F neomutation and
344 hydrophobic C-terminal domain G175R mutation in two pedigrees with severe
345 hyperchylomicronemia. *J Clin Endocrinol Metab.* 2011;96:E1675-9.

- 346 [17] Berge KE, Retterstol K, Romeo S, Pirazzi C, Leren TP. Type 1 hyperlipoproteinemia
347 due to a novel deletion of exons 3 and 4 in the GPIHBP1 gene. *Atherosclerosis*.
348 2014;234:30-33.
- 349 [18] Rios JJ, Shastry S, Jasso J, Hauser N, Garg A, Bensadoun A, Cohen JC, Hobbs HH.
350 Deletion of GPIHBP1 causing severe chylomicronemia. *J Inher Metab Dis*.
351 2012;35:531-540.
- 352 [19] Buonomo PS, Bartuli A, Rabacchi C, Bertolini S, Calandra S. A 3-day-old neonate
353 with severe hypertriglyceridemia from novel mutations of the *GPIHBP1* gene. *J Clin*
354 *Lipidol*. 2015; 9:265-270.
- 355 [20] Bengston-Olivecrona G, Olivecrona T. Assay of lipoprotein lipase and hepatic
356 lipase. In Converse C.A. & Skinner E.R. editors. *Lipoprotein analysis: a practical*
357 *approach*. IRL Press. Oxford 1992:169-185.
- 358 [21] Ariza MJ, Sanchez-Chaparro MA, Baron FJ, Hornos AM, Calvo-Bonacho E, Rioja J,
359 Valdivielso P, Gelpi JA, Gonzalez-Santos P. Additive effects of LPL, APOA5 and APOE
360 variant combinations on triglyceride levels and hypertriglyceridemia: results of the
361 ICARIA genetic sub-study. *BMC Med Genet*. 2010;11:66-2350-11-66.
- 362 [22] Coca-Prieto I, Valdivielso P, Olivecrona G, Ariza MJ, Rioja J, Font-Ugalde P, Garcia-
363 Arias C, Gonzalez-Santos P. Lipoprotein lipase activity and mass, apolipoprotein C-II
364 mass and polymorphisms of apolipoproteins E and A5 in subjects with prior acute
365 hypertriglyceridaemic pancreatitis. *BMC Gastroenterol*. 2009;9:46-230X-9-46.
- 366 [23] Coca-Prieto I, Kroupa O, Gonzalez-Santos P, Magne J, Olivecrona G, Ehrenborg E,
367 Valdivielso P. Childhood-onset chylomicronaemia with reduced plasma lipoprotein
368 lipase activity and mass: identification of a novel GPIHBP1 mutation. *J Intern Med*.
369 2011;270:224-228.
- 370 [24] Wang J, Hegele RA. Homozygous missense mutation (G56R) in
371 glycosylphosphatidylinositol-anchored high-density lipoprotein-binding protein 1 (GPI-
372 HBP1) in two siblings with fasting chylomicronemia (MIM 144650). *Lipids Health Dis*.
373 2007;6:23.
- 374 [25] Beigneux AP, Franssen R, Bensadoun A, Gin P, Melford K, Peter J, Walzem RL,
375 Weinstein MM, Davies BS, Kuivenhoven JA, Kastelein JJ, Fong LG, Dallinga-Thie GM,
376 Young SG. Chylomicronemia with a mutant GPIHBP1 (Q115P) that cannot bind
377 lipoprotein lipase. *Arterioscler Thromb Vasc Biol*. 2009;29:956-962.
- 378 [26] Franssen R, Young SG, Peelman F, Hertecant J, Sierts JA, Schimmel AW, Bensadoun
379 A, Kastelein JJ, Fong LG, Dallinga-Thie GM, Beigneux AP. Chylomicronemia with low
380 postheparin lipoprotein lipase levels in the setting of GPIHBP1 defects. *Circ Cardiovasc*
381 *Genet*. 2010;3:169-178.
- 382 [27] Olivecrona G, Ehrenborg E, Semb H, Makoveichuk E, Lindberg A, Hayden MR, Gin
383 P, Davies BS, Weinstein MM, Fong LG, Beigneux AP, Young SG, Olivecrona T, Hernell O.

- 384 Mutation of conserved cysteines in the Ly6 domain of GPIHBP1 in familial
385 chylomicronemia. *J Lipid Res.* 2010;51:1535-1545.
- 386 [28] Gonzaga-Jauregui C, Mir S, Penney S, Jhangiani S, Midgen C, Finegold M, Muzny
387 DM, Wang M, Bacino CA, Gibbs RA, Lupski JR, Kellermayer R, Hanchard NA. Whole-
388 exome sequencing reveals GPIHBP1 mutations in infantile colitis with severe
389 hypertriglyceridemia. *J Pediatr Gastroenterol Nutr.* 2014;59:17-21.
- 390 [29] Ahmad Z, Wilson DP. Familial chylomicronemia syndrome and response to
391 medium-chain triglyceride therapy in an infant with novel mutations in GPIHBP1. *J Clin*
392 *Lipidol.* 2014;8:635-639.
- 393 [30] Beigneux AP, Davies BS, Tat S, Chen J, Gin P, Voss CV, Weinstein MM, Bensadoun
394 A, Pullinger CR, Fong LG, Young SG. Assessing the role of the
395 glycosylphosphatidylinositol-anchored high density lipoprotein-binding protein 1
396 (GPIHBP1) three-finger domain in binding lipoprotein lipase. *J Biol Chem.*
397 2011;286:19735-19743.
- 398 [31] Evans D, Arzer J, Aberle J, Beil FU. Rare variants in the lipoprotein lipase (LPL) gene
399 are common in hypertriglyceridemia but rare in Type III hyperlipidemia.
400 *Atherosclerosis.* 2011;214:386-390.
- 401 [32] Yu XH, Zhao TQ, Wang L, Liu ZP, Zhang CM, Chen R, Li L, Liu G, Hu WC. A novel
402 substitution at the translation initiator codon (ATG-->ATC) of the lipoprotein lipase
403 gene is mainly responsible for lipoprotein lipase deficiency in a patient with severe
404 hypertriglyceridemia and recurrent pancreatitis. *Biochem Biophys Res Commun.*
405 2006;341:82-87.
- 406 [33] Fojo SS, De Gennes JL, Chapman J, Parrot C, Lohse P, Kwan SS, Truffert J, Brewer
407 HB, Jr. An Initiation Codon Mutation in the ApoC-II_{Paris} Gene (ApoC-II_{Paris}) of a Patient with
408 a Deficiency of Apolipoprotein C-11. *J Biol Chem.* 1989;264:20839-20842.
- 409 [34] Kozak M. An analysis of 5'-noncoding sequences from 699 vertebrate messenger
410 RNAs. *Nucleic Acids Res.* 1987;15:8125-8148.
- 411 [35] De Caterina R, Talmud PJ, Merlini PA, Foco L, Pastorino R, Altshuler D, Mauri F,
412 Peyvandi F, Lina D, Kathiresan S, Bernardinelli L, Ardissino D, Gruppo Italiano
413 Atherosclerosi. Strong association of the APOA5-1131T>C gene variant and early-onset
414 acute myocardial infarction. *Atherosclerosis.* 2011;214:397-403.
- 415 [36] Brito DD, Fernandes AP, Gomes KB, Coelho FF, Cruz NG, Sabino AP, Cardoso JE,
416 Figueiredo-Filho PP, Diamante R, Norton CR, Sousa MO. Apolipoprotein A5-1131T>C
417 polymorphism, but not APOE genotypes, increases susceptibility for dyslipidemia in
418 children and adolescents. *Mol Biol Rep.* 2011;38:4381-4388.
- 419 [37] Guardiola M, Ribalta J, Gomez-Coronado D, Lasuncion MA, de Oya M, Garces C.
420 The apolipoprotein A5 (APOA5) gene predisposes Caucasian children to elevated
421 triglycerides and vitamin E (Four Provinces Study). *Atherosclerosis.* 2010;212:543-547.

422

423 **Title and legend to figures**

424 **Figure 1. Pedegrees of proband 1 (A) and proband 2 (B).** Proband is designated with filled
425 symbols. The question marks (?) denote individuals who could not be studied.

426 **Figure 2. *GPIPHBP1* sequences showing the mutations found in our patients.** Panel 1.a shows
427 the normal sequence and 1.b the homozygous C>A transversion at the second base of codon
428 80 in exon 3, resulting in a conversion of threonine to lysine found in proband 1. Panel 2.a
429 shows the normal sequence and 2.b the homozygous G>T transversion at the third base of
430 codon 1 in exon 1, resulting in a conversion of the first methionine to isoleucine found in
431 proband 2. The sequence in panel 2.c corresponds to the youngest brother of proband 2 who
432 is heterozygous for the mutation.

433

Table 1. Anthropometric, biochemical and genetic data

Subject	Age	BMI (Kg/m ²)	TC (mg/dL)	HDL-C (mg/dL)	TG (mg/dL)	Max. TG (mg/dL)	ApoCII (mg/dL)	LPL activity (mU/mL)	Mutation in GPIHBP1	SNPs
P1 (A.II-1)	39	26,6	119	15	1270	4489	29,9	3.7	Homozygous rare allele c.239 C>A, ACG>AAG, Thr ₈₀ >Lys	None
P2 (B.II-1)	25	21,6	299	14	1384	3820	7.5	9.5	Homozygous rare allele c.3 G>T, ATG>ATT, Met ₁ >Ile	Homozygous rare allele rs3135506 (<i>APOA5</i>)
P2 mother (B.I-2)	43	23,7	211	52	58		ND	ND	Heterozygous c.3 G>T, ATG>ATT, Met ₁ >Ile	Heterozygous rs3135506 (<i>APOA5</i>)
P2 brother (B.II-2)	24	23,9	154	45	59		ND	ND	Absent	Homozygous rare allele rs3135506 (<i>APOA5</i>)
P2 sister (B.II-3)	17	25,1	183	47	86		ND	ND	Absent	None
P2 brother (B.II-4)	6	15,2	174	54	77		ND	ND	Heterozygous c.3 G>T, ATG>ATT, Met ₁ >Ile	Heterozygous <i>APOA5</i> SNPs rs3135506 and rs662799

Subject: P: proband. The subject's code according to the pedigrees displayed in figure 1 is indicated in parentheses. **BMI:** body mass index. **TC:** total cholesterol. **TG:** triglycerides. **HDL-C:** cholesterol in high density lipoproteins. **Max. TG:** highest level of triglyceride reported. **ApoCII:** Apolipoprotein C2. **SNPs:** Single nucleotide polymorphisms. *APOE* (rs429358 and rs7412, alleles $\epsilon 2$, $\epsilon 3$ and $\epsilon 4$) and *APOA5* (rs662799 and rs3135506) common variants were screened.

Table 2. Mutations found in the GPIHBP1 gene in severe hypertriglyceridemic patients

Report	Mutation (HO: homozygous; CHE; compound heterozygous)	Patient code	Gender, age	Origin	PC	Pancreatitis (age of onset)	Associated symptoms	Max. TG	Min. TG
Wang J. and Hegele R.A; 2007 ²⁴	c.166 G>C, p.G56R (HO)	II-3	F, 47 y	NA	No	RP (22 y)	NO	7120	≈886
	c.166 G>C, p.G56R (HO)	II-1	M, 52 y	NA	No	RP (25 y)	CHD	4272	≈886
Beigneux A.P. et al.; 2009 ²⁵	c.344 A>C, p.Q115P (HO)	P	M, 33 y	Columbian	NA	No	HSM	3366	774
Franssen R. et al.; 2010 ²⁶	c.194 G>A, p.C65Y (HO)	P	M, 3 y	Arabian	Yes	Yes (1 y)	LR	4005	1575
Olivecrona G. et al.; 2010 ²⁷	c.194 G>C, p.C65S + c.202 T>G, p.C68G (CHE)	II-3	M, 13 y	Swedish	No	No	SM	1727	638
	c.194 G>C, p.C65S + c.202 T>G, p.C68G (CHE)	II-2	F, 18 y	Swedish	No	Abdominal pain	LR	5049	NA
	c.194 G>C, p.C65S + c.202 T>G, p.C68G (CHE)	II-4	F, 2 y	Swedish	No	Yes (childhood)	HSM	4296	NA
Charriere S. et al.; 2011 ¹⁶	c.266 G>T, p.C89F + c.1-?_2282+?del (gene del), p.0 (HO)	AII-1	M, 6 m	NA	No	Yes (6 m)	NO	1736	266
	c.523G>C, p.G175R (HO)	BII-2	M, 26 y	Algerian	No	RP	NO	5757	≈886
Coca-Prieto I. et al.; 2011 ²³	c.203G>A, p.C68Y (HO)	C	F, 30 y	Spanish	No	Yes (6 y)	NO	1398	≈886
Rios J.J. et al.; 2012 ¹⁸	17499bp del, including GPIHBP1, p.0 (HO)	A.V-1	M, 2 m	Asian indian	No	No	LR	37248	905
	17499bp del, including GPIHBP1, p.0 (HO)	A.III-9	F, 44 y	Asian indian	No	Yes (29 y)	NA	981	NA
	c.203G>A, p.C68Y (HO)	B.II-7	F, 36 y	Salvadoran	No	Yes (24 y)	EX	6484	NA
Surendran R.P., et al.; 2012 ¹⁴	c.194G>A, p.C65Y (HO)	P	NA	NA	NA	NA	NA	>886	NA
	c.323C>G, p.T108R (HO)	P	M, 1 y	NA	NI	Yes	NO	>886	381
	c.344 A>C, p.Q115P (HO)	P	NA	NA	NA	NA	NA	>886	NA
Yamamoto H. et al., 2013 ¹³	c.202T>C, p.C68R (HO)	P	F, 54 y	Japanese	Yes	RP (27 y)	CAD	2640	790

Table 2. Continued

Report	Mutation (HO: homozygous; CHE; compound heterozygous)	Patient code	Gender, age	Origin	PC	Pancreatitis (age of onset)	Associated symptoms	Max. TG	Min. TG
Berge K.E. et al.; 2014 ¹⁷	c.182-?_555+?del (Ex3-4 del), p.0 (HO)	VI:2	F, 22 y	Pakistani	Yes	RP	NA	5314	NA
	c.182-?_555+?del (Ex3-4 del), p.0 (HO)	VI:1	M, 37 y	Pakistan	Yes	RP	NA	8857	NA
	c.182-?_555+?del (Ex3-4 del), p.0 (HO)	VI:3	M, 40 y	Pakistani	Yes	No	NA	>3543	NA
	c.182-?_555+?del (Ex3-4 del), p.0 (HO)	VI:4	F, 37 y	Pakistan	Yes	RP	NA	2391	NA
Gonzaga-Jauregui C. et al.; 2014 ²⁸	c.331A>C, p.T111P + c.413_429del, p.P140Sfs*161 (CHE)	P	F, 5 w	Hispanic	No	Yes (2 y)	EX	12031	626
Plengpanich W. et al., 2014 ¹²	c.320C>G, p.S107C (HO)	II-8	F, 46 y	Thai	No	Abdominal pain	NO	6448	505
	c.320C>G, p.S107C (HO)	II-1	M, 64 y	Thai	No	NA	NA	842	NA
	c.320C>G, p.S107C (HO)	II-10	M, 43 y	Thai	No	NA	NA	673	NA
Ahmad Z. et al., 2014 ²⁹	c.267C>A, p.C89* + c.85-88GAGGdel, p.E29Tfs*50 (CHE)	P	F, 6 m	Caucasian	No	Yes	EX	2665	423
Buonuomo P.S. et al., 2015 ¹⁹	c.154-162AACAGGCTdelTCTTins, p.N52Sfs*253 + c.319 T>C, p.S107P (CHE)	P	F, 3 d	Italian	No	No	NO	1667	235
This report	c.239 C>A, p.T80K (HO)	A.II-1	M, 37 y	Pakistani	Yes	RP (23 y)	NO	4489	≈1000
	c.3 G>T, p.M1I (HO)	B.II-1	F, 25 y	Ecuadorian	Yes	RP (15 y)	NO	3820	343

NA (throughout the table): data not available. **Patient code:** code given to each particular patient in the original reference. When there are more than one member of the same family the proband is listed the first. P: no code is given either because one single proband or unrelated patients are studied. **Gender and age:** M: male, F: female, y: years, m: months, w: weeks, d: days. **PC:** reported parent's consanguinity. In references 24 and 27 common ancestors are suspected. **Pancreatitis:** it is indicated whether the patient suffered or not from pancreatitis (Yes/ No) or just abdominal pain. RP: recurrent pancreatitis. The age of the first episode is indicated in parentheses when available. **Associated symptoms:** CHD: coronary heart disease, NO: not observed, HSM: hepatosplenomegaly, LR: lipemia retinalis, SM: splenomegaly. **Max. TG:** highest triglyceride level reported for each patient. **Min. TG:** lowest triglyceride level achieved for each patient under different treatments and formula diets. The common *GPIHBP1* variant p.C14F, rs11538389 is described in references 13 and 16 and the variant p.S144F, rs78367243 is found in reference 14. References 13, 16, 17, 23-28 and this report include information on LPL activity. ApoCII levels are given in references 13, 23, 25, 26 and in this report. *In vitro* functional analyses of the mutations are carried out in reports 12, 13, 16, 25-27.

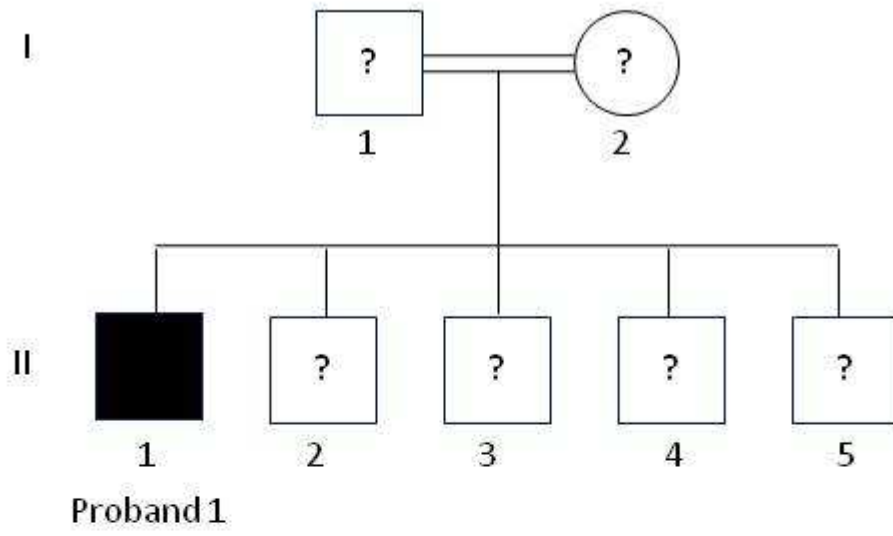
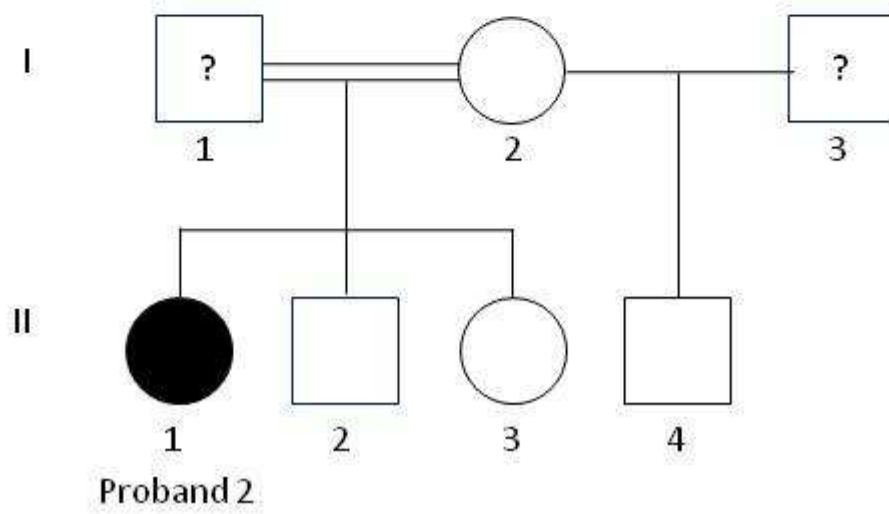
A**B**

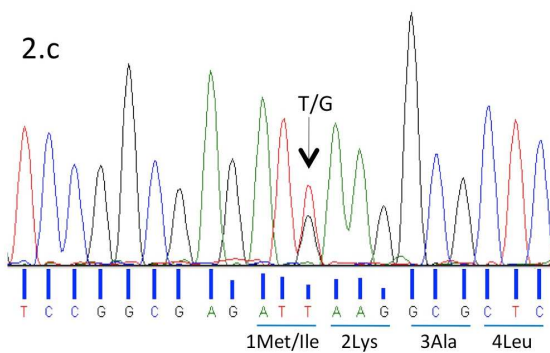
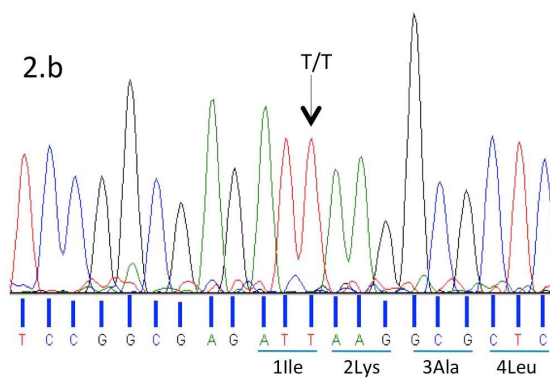
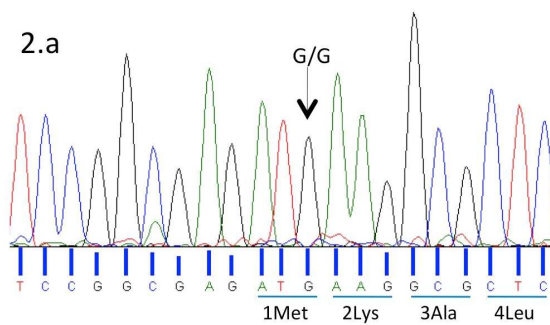
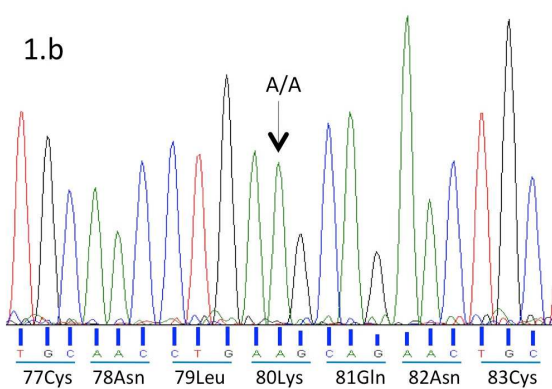
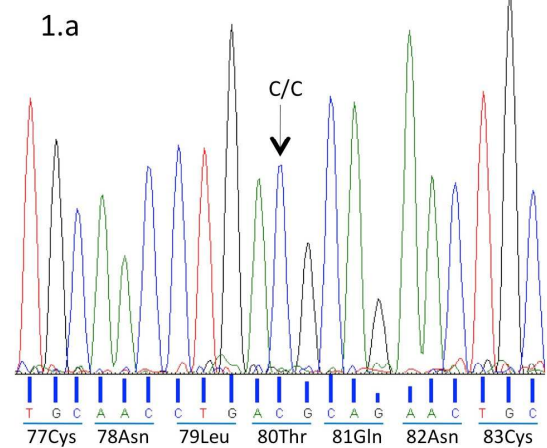

ACCEPTED

- We studied two patients with recurrent pancreatitis and severe hypertriglyceridemia
- Patients exhibited low lipoprotein lipase activity but no rare variants in this gene
- We identified two novel missense mutations in the *GPIHBP1* gene
- One patient was homozygous for the mutation c.239 C>A, ACG>AAG, p.Thr₈₀>Lys
- The other patient was homozygous for the mutation c.3 G>T, ATG>ATT, p.Met₁>Ile

ACCEPTED MANUSCRIPT

Supplementary Table S1

<i>LPL</i> sequencing			
	Variants	Region	State
Proband 1	No variants found	-	-
Proband 2	c.1164 C>A, ACC>ACA, Thr361>Thr	Exon 8	Heterozygosity

<i>APC2</i> sequencing			
	Variants	Region	State
Proband 1	IVS3+38_40 del 3bp (ACC)	IVS3	Homozygosity
Proband 2	UTR5' -109 G>C	UTR 5'	Heterozygosity
	UTR 5' -24 G>T	UTR 5'	Heterozygosity
	IVS1-67 G>T	IVS1	Homozygosity
	IVS3+38_40 del 3bp	IVS3	Homozygosity
	IVS3-151 C>G	IVS3	Heterozygosity
	IVS3-150_-148 del 3bp	IVS3	Heterozygosity
	IVS3-81 C>T	IVS3	Heterozygosity