

1 **A NOVEL HUMID ELECTRONIC NOSE COMBINED WITH AN ELECTRONIC TONGUE**
2 **FOR ASSESSING DETERIORATION OF WINE**

3 **Luis Gil-Sánchez^{a,b,*}, Juan Soto^{a,c,*}, Ramón Martínez-Máñez^{a,c,d}, Eduardo Garcia-Breijo^{a,b},**
4 **Javier Ibáñez^{a,b}, Eduard Llobet^e**

5 ^a*Centro de Reconocimiento Molecular y Desarrollo Tecnológico (IDM), Unidad Mixta Universidad*
6 *Politécnica de Valencia – Universidad de Valencia, Spain*

7 ^b*Departamento de Ingeniería Electrónica. Universidad Politécnica de Valencia, Camino de Vera s/n.*
8 *E-46022 Valencia, Spain*

9 ^c*Departamento de Química. Universidad Politécnica de Valencia, Camino de Vera s/n. E-46022*
10 *Valencia, Spain.*

11 ^d*CIBER de Bioingeniería, Biomateriales y Nanomedicina (CIBER-BBN)*

12 ^e*MINOS-EMaSf, Department Enginyeria Electrònica, Universitat Rovira i Virgili (Tarragona - Spain)*

13 *Corresponding author: Luis Gil-Sánchez, Phone: 34-963877608, Fax: 34-963877609, e-mail:
14 lgil@eln.upv.es

15
16 **Abstract:** We report herein the use of a combined system for the analysis of the spoilage of wine
17 when in contact with air. The system consists of a potentiometric electronic tongue and a humid
18 electronic nose. The potentiometric electronic tongue was built with thick-film serigraphic techniques
19 using commercially available resistances and conductors for hybrid electronic circuits; i.e. Ag, Au,
20 Cu, Ru, AgCl, and C. The humid electronic nose was designed in order to detect vapours that emanate
21 from the wine and are apprehended by a moist environment. The humid nose was constructed using a
22 piece of thin cloth sewn, damped with distilled water, forming five hollows of the right size to
23 introduce the electrodes. In this particular case four electrodes were used for the humid electronic
24 nose: a glass electrode, aluminium (Al), graphite and platinum (Pt) wires and an Ag-AgCl reference
25 electrode. The humid electronic nose together with the potentiometric electronic tongue were used for
26 the evaluation of the evolution in the course of time of wine samples. Additionally to the analysis
27 performed by the tongue and nose, the spoilage of the wines was followed via a simple determination
28 of the titratable (total) acidity.

29 **Keywords:** Electronic tongue, electronic nose, wine quality
30

31 INTRODUCTION

32 The determination of wine quality has always been a dynamic field of research. The main constituents
33 of wine are water, ethanol and acids, but the elements that distinguish one wine from another, namely,
34 their quality, area of origin, vintage, etc are a large number of constituent components that are present
35 in very small proportions. Besides, the wine can be considered as a living product because its
36 chemical and organoleptic characteristics change over time. This makes the analysis of wine a rather
37 difficult task because, in addition to the determination of key components in small proportions,
38 analysis must be performed in different stages of its manufacture, storage and consumption. Another
39 reason for the interest in wine analysis resides in the quality control and detection of possible
40 adulterations or spoilage. Currently the basic technique to assess wine quality is the use of a panel of
41 trained experts that carry out sensory analysis based on colour, taste and flavour. However this is often
42 time-consuming and requires skilled personnel. Therefore, there is an increasing interest in the
43 development of low-cost, easy-to-use analytical protocols able to *in situ* and *at site* monitoring wine
44 quality. In this context the use of electronic tongues and noses is a timely research field and a good
45 alternative to be used in the characterization of wines and other foodstuffs [1,2].

46 Electronic noses or tongues are inspired in the mode mammals recognize samples via
47 olfaction and taste senses. In this approach, sensors do not have to be selective but to respond
48 unspecifically to a group of related chemical species. The sensors are then integrated in an array and
49 their response is analysed by suitable pattern recognition procedures. These systems usually display
50 comparative/qualitative rather than quantitative information. Several research groups have developed
51 gas multisensor systems to determine the aroma of wine using electronic noses based on metal oxides,
52 such as SnO₂ [3,4], WO₃ [5], surface acoustic wave (SAW) devices [6] or gas chromatography–mass
53 spectrometry GC–MS [7] and compared their performance with sensory analysis [8]. In most cases
54 electronic noses commonly use resistive sensors, whose impedance varies with the presence of certain
55 gases. However it has been reported that the analysis of alcoholic beverages with semiconductor-
56 based electronic noses is a difficult task due to the presence of high ethanol and water concentrations,
57 which tend to mask the presence of other important volatile compounds and contribute to the
58 shortening of sensor life [9]. In that sense, various solutions for dehydration and dealcoholisation of
59 wine samples have been proposed. [10].

60 On the other hand, electronic tongues have also been used for the analysis of wines employing
61 arrays of electrochemical Langmuir-Blodgett film sensors and voltammetry [11], impedance
62 spectroscopy [12], amperometry [13] or potentiometry [14]. In relation to sensor technologies, thin-
63 film electrodes have been used for the analysis of white wines and artificial wines [15]. Additionally it
64 should be noted that some authors have studied the possibility of using a combination of electronic

65 noses and tongues for wine analysis, [16,17] whereas more advanced systems combining electronic
66 nose, electronic tongue and an electronic eye have also been reported [18].

67 Following our interest in the design of electronic tongues and noses [19] we report on the use
68 of a combined system for the analysis of the spoilage of wine when in contact with air. The system
69 consists of a potentiometric electronic tongue and a humid electronic nose. The latter, in contrast to
70 resistive sensors employed in electronic noses, uses electrodes that are placed on a wet setting. This
71 proposed system detects vapours that emanate from the wine and are apprehended by a moist
72 environment. The design of such a humid electronic nose as far as we know, is new and allows the use
73 of classical electrochemical techniques commonly employed in e-tongues for the analysis of volatile
74 compounds. In this paper we report the use of such a humid electronic nose together with a
75 potentiometric electronic tongue for the evaluation of the time evolution of wine samples.

76

77 **MEASUREMENT SYSTEM**

78 The measurement system used consists of two arrays of electrodes, for the humid electronic nose and
79 for the electronic tongue, that are attached to a common measurement equipment. The measurement
80 set is formed by a signal conditioning system, which comprises amplifiers with very high impedance
81 and filters for rejecting the 50 Hz noise, a system for data acquisition and a multivariate data analysis
82 engine (Fig. 1). This measurement system is self-built. Details of its construction have been reported
83 elsewhere [20].

84

85 *Insert here Figure 1*

86

87 Electronic Tongue Electrodes

88 In order to make the electronic tongue, a potentiometric measurement system has been developed,
89 which consists of electrodes built employing thick-film serigraphic techniques. The pastes are
90 commercially available and commonly used in the manufacture of thick-film resistances and
91 conductors for hybrid electronic circuits. Each one of these pastes has an active element, which we
92 employed to obtain potentiometric electrodes. The active elements are: Ag, Au, Cu, Ru, AgCl, and C.
93 Although in the electronic tongue these materials are used as non-specific electrodes, their properties
94 as suitable surfaces sensitive to chemical species have already been studied [21]. Some materials have
95 been duplicated on the multisensor system, finally obtaining 9 potentiometric electrodes. Fig. 2 shows

96 the electrode distribution on the multisensor board and the tracks and pads for connecting the board
97 using a flat wire. More details can be found elsewhere [22].

98
99 *Insert here Figure 2*

100 101 The Humid Electronic Nose

102 The humid electronic nose was inspired in biological olfaction which needs a wet medium for the
103 absorption of volatile components. The humid electronic nose was constructed using a piece of thin
104 cloth, sewn forming five hollow spaces of the appropriate size to introduce five different wire
105 electrodes (i.e. four active electrodes and one reference electrode). Electrodes are tightly fit so a
106 perfect contact between the electrode and the cloth is accomplished. In order to achieve a good
107 conductivity between the active electrodes and reference electrode the cloth was damped with distilled
108 water. Appropriate results were obtained using nylon textiles. Fig. 3 shows a scheme of the humid
109 nose. Volatile compounds in wine will evaporate and will be dissolved in the damp fabric where the
110 potentiometric electrodes are included. In this particular case four electrodes were used for the humid
111 electronic nose: a glass electrode, aluminium (Al), graphite and platinum (Pt) wires and an Ag-AgCl
112 reference electrode. All electrodes were placed in a glass container tightly closed to prevent contact
113 with external vapours

114
115 *Insert here Figure 3*

116 117 **EXPERIMENTS**

118 Samples

119 Three Spanish table wines were analyzed with the humid electronic nose and the electronic tongue
120 combined system; i.e. two red and one white wine. The red wines were labelled RA and RB and the
121 white wine was labelled W. All the wine bottles were opened on the same day, and measurements
122 were made on days 1, 5, 9, 15, 19, 22, 28, 36 and 48. During these days the bottles remained opened.
123 Wines were stored at a constant temperature of 15°C. Each working day the wines were measured
124 using the humid electronic nose and the electronic tongue. Also each working day the total titratable
125 acidity was measured for all three wines.

126 Acidity Determination

127 Titratable (total) acidity in wines was determined by simple acid–base titration using NaOH with
128 either visual or potentiometric detection.

129 Measurement using the electronic tongue and the humid electronic nose

130 To perform the measurements with the electronic tongue system the multisensor board (see Fig. 2)
131 containing an Ag-AgCl reference electrode, was dipped into a vessel containing the corresponding
132 wine sample. Then the potential between each active electrode and the reference electrode was
133 measured. Measurements were performed automatically by sampling every five seconds during a time
134 of about ten minutes to achieve electrochemical stability.

135 To make measurements with the humid electronic nose the corresponding wine was poured
136 into a container that comprised the set of electrodes wrapped by a damp fabric and the system was
137 sealed. Thus, volatiles emanating from the wine permeated the wet cloth, changing the characteristics
138 of the electrochemical cells formed by an active electrode and the reference electrode. Similar to the
139 electronic tongue system, the potential between each electrode and the reference electrode was
140 measured for ten minutes in order to reach electrochemical stability. After each measurement, the
141 damp cloth was removed and the electrodes were careful cleaned with distilled water in order to
142 remove all traces of previous experiences.

143 For both the electronic nose and the humid electronic nose a standard solution was prepared.
144 Before measurements with the wine samples the set of electrodes were dipped in buffered water at pH
145 5 (standard solution) and the potential for each electrode was measured. This was set as a zero
146 reference value. The data for the posterior analysis with the wine samples was taken as the difference
147 between the zero reference and the measured potential for each sample.

148 The final data array contained of 27 rows (3 wines x 9 days) and 13 columns (electrodes from
149 the humid electronic nose (4) and from the electronic tongue (9)).

150

151 **RESULTS**

152 As stated above, following our interest in the design of electronic tongues and noses for different
153 applications, we attempted to apply the use of these devices to the analysis of the spoilage of wine
154 when in contact with air. In the first step a potentiometric electronic tongue was used. The electronic
155 tongue consisted of a set of electrodes built with thick-film serigraphic techniques. The active
156 elements in the electrodes were: Ag, Au, Cu, Ru, AgCl, and C (see experimental section). Despite the
157 fact that similar electronic tongues have been used by some of us in certain applications such as in fish
158 freshness analysis, [23] in this case, the tongue barely was able to discriminate the evolution of the
159 samples through time (data not shown) in the wine spoilage process. In this particular case, this low

160 discrimination using the electronic tongue may be attributed to the possible masking ability of water
161 and ethanol that are found in very high concentrations in wine samples. Therefore it occurred to us
162 that a combination of tongue and nose might be more suitable for monitoring the evolution of wine
163 through time due to the presence, after some time, of volatile derivatives usually associated to wine
164 spoilage (vide infra). Additionally we were especially interested in the design of a humid electronic
165 tongue as a suitable alternative to the use of classical electronic noses based on metal oxides. One
166 advantage of this humid electronic tongue, that was designed to evaluate the presence of volatile
167 compounds, is the possibility of using typical electrochemical electrodes such as those usually found
168 in electronic tongues. The nose involves the use of potentiometric electrodes (wires of Al, C
169 (graphite), Pt and a glass electrode) and a reference electrode (Ag-AgCl) that are placed in a damp
170 cloth sewn. We used such humid electronic nose in combination with a potentiometric electronic
171 tongue for monitoring the evolution of wine with time. As stated above for this set of experiments
172 three wines were used; i.e. two red wines (RA and RB) and one white wine (W). The wine bottles
173 were opened the same day and measurements were made at days 1, 5, 9, 15, 19, 22, 28, 36 and 48
174 after they were opened.

175

176 *Insert here Figure 4*

177

178 Wine is a complex mixture of compounds that usually derive from three major sources; i.e.
179 grapes, microorganism and (if used) oak. Additionally wine spoilage is a rather complex process in
180 which acetic acid bacteria play an important role because their metabolites result in disagreeable wine
181 sensory characteristics. The concentration of acetic acid in wine is an important parameter because it
182 is the head of the deterioration process of the wine, causing the spoilage effect that set the wine a
183 vinegary taste. Acetic acid is the major volatile acid in wine and the main constituent of wine volatile
184 acidity and is usually considered undesirable in wines. At high concentrations, acetic acid gives a sour
185 flavour and a vinegar-like aroma. Acetic acid is produced by bacteria through the metabolism from
186 ethanol to acetaldehyde to acetic acid. Both volatile intermediate metabolites acetaldehyde and ethyl
187 ester of acetic acid also contribute to the sensory spoilage of wine. [24,25] Whereas in the spoilage of
188 wine process other acids such as citric acid and malic acid remain at the same concentrations, the
189 amount of acetic acid, ethyl acetate and acetaldehyde increases significantly. Therefore, as a simple
190 control of wine spoilage as a function of time we determined the titratable (total) acidity in wines RA,
191 RB and W by simple acid–base titrations at days 1, 5, 9, 15, 19, 22, 28, 36 and 48. The results are
192 shown in Fig. 4. The acidity measurements reveal that, for all wine types, little variation occurs in the

193 first days and a sharp increase in acidity is observed in the last days. Note also that the variation of
194 acidity slightly depends on the type of wine.

195 Results independently of the electronic tongue and the electronic nose

196 A suitable mode to interpret the results obtained from the use of the electronic tongue and the humid
197 electronic nose on the different wine samples is to use multivariate analysis which is a statistical
198 method able to determine the contribution of various factors on a single event. To perform this type of
199 analysis Matlab 2010 with the appropriate Toolbox (PLS_Toolbox and Statistics Toolbox) has been
200 used. One of the methods most commonly used of multivariate analysis is Principal Component
201 Analysis (PCA). For this purpose, new orthogonal directions in the variable space are searched, called
202 Principal Components (PC). The representation of the first two principal components (PC1 and PC2)
203 in a two-dimensional graphic often provides a fairly significant result of the actions and behavior of
204 the system. [26]

205 PCA analysis of the results of the electronic tongue shows a good discrimination of the measures of
206 the some days (1, 5, 9, 22, 28 and 36) but not discrimination on the last day (48). Comparing these
207 results with those obtained in the measure of acidity it suggests that the cause of discrimination
208 obtained by the electronic tongue is different from the change in the acidity of the wine. In contrast, in
209 the PCA analysis of the results of the electronic nose stands out a clear discrimination measures for
210 the last tested day (48). This suggests that the response of the electronic nose is related to the increase
211 in acidity. Results independently of the electronic tongue and the electronic nose are shown in Fig. 5.

212 *Insert here Figure 5*

213

214 Result combining the electronic tongue and the electronic nose

215 The results obtained independently from the electronic tongue and the electronic nose suggest that
216 from the combination of both results it could be possible to monitorize the evolution of wine as a
217 function of the days elapsed since the bottle was opened. In fact is observed in Fig. 6 that shows the
218 first two principal components of a PCA of data from the combined electronic tongue and humid
219 electronic nose systems. Samples of three wines RA, RB and W of a given day appear close to each
220 other. While the content of acetic acid in wine increases slightly (i.e., from day 1 to day 36), the scores
221 of the wines tested move from right to left along the first principal component. On day 48, a strong
222 variation in the second principal component is observed. This may be due to the sharp increase in the
223 concentration of acetic acid 48 days after the bottles were opened but also to the occurrence of other
224 compounds associated to wine degradation. It is interesting to note that the system is capable of

225 distinguishing the measurements of the first days, despite the fact that acidity measurements of those
226 days were almost identical. That is, the proposed system appears to be able to detect components that
227 do not directly affect the acidity of wine. One of the main problems when using metallic electrodes is
228 the possible occurrence of response or baseline drift that could lead to obtain irreproducible data or to
229 mistakenly believe that drift variations are changes in wine spoilage. In order to control these possible
230 drifts, prior to the measurement of the wine samples, the electrodes were immersed in an aqueous
231 sample (25 °C buffered at pH 5, standard solution) and the data for the posterior analysis were taken
232 as the difference between the zero reference and the measured potential for each wine sample.

233
234 *Insert here Figure 6*

235
236 In order to understand the relationship between the diverse electrodes used, the loads of each
237 electrode in the first two Principal Components are shown in Fig. 7. This figure helps to verify the
238 different significance of the electrodes in the electronic nose respect the ones used in the electronic
239 tongue. The loads of the electronic tongue electrodes are on the left-hand side of the plot (loads on
240 PC1 are negative), all of them with a homogenous activity.

241 Glass, Aluminium and Platinum electrodes of the humid electronic nose show very different
242 loads with respect of the electronic tongue ones, that is to say, the former electrodes are independent
243 of the latter. These electrodes, which appear in the upper side of Fig. 7, are responsible for the position
244 of measurements performed the last day (48), which appear apart in the score plot (Fig. 6). A possible
245 chemical interpretation of these results is that the last day (48) the wines give off aromas with a higher
246 acidity than in previous days because wines are soured.

247 Fig. 7 also shows that the different electrodes significantly contribute to the first two principal
248 components. Only the loads of the graphite electrode are close to zero. In fact this electrode had an
249 erratic behaviour and could be removed from the set of electrodes without significant changes in the
250 PCA scores plot.

251 *Insert here Figure 7*

252
253 By selecting the first two principal components in the principal component analysis, only
254 69.38% of the data variance (i.e. information) provided by the electronic tongue and humid electronic
255 nose are actually used. This value is not very high, which means that there is not a high degree of
256 correlation between the different electrodes employed. This fact is quite logical due to the different
257 nature of the electrodes employed in the electronic tongue and humid electronic nose.

258 To achieve an analysis in which all the information (i.e. all data variance) from the electronic
259 tongue and the humid electronic nose is used, a cluster analysis with dendrograms has been
260 performed. A dendrogram acts as genealogical tree of the measurements. The measurements are
261 associated to each other to complete the tree. To obtain a dendrogram different algorithms can be
262 employed but the most commonly used is K-means clustering. This algorithm aims to partition n
263 observations into k clusters in which each observation belongs to the cluster with the nearest mean
264 [27]. Fig, 8 shows the dendrogram obtained when a k-means clustering is applied to the wine data.
265 Measurements performed at day 48 are clearly different from any other measurement performed
266 before and appear grouped in a single cluster. Two other clusters can be easily inferred, which group
267 together measurements performed between days 1 to 9 and from days 15 to 36, respectively. If we
268 consider now the cluster grouping measurements from day 1 to day 9, measurements of the first day
269 are clearly different from the others suggesting that early stages of wine evolution can be detected. For
270 the cluster that groups measurements performed between days 15 and 36, the initial and last
271 measurements within this group (i.e. those of day 15 and day 36) appear clearly discriminated in the
272 dendrogram. These results are consistent with those obtained in the PCA plot.

273

274 *Insert here Figure 8*

275 **CONCLUSIONS**

276 In summary we have combined a potentiometric electronic tongue with a humid electronic nose and
277 have applied the joint electronic system to the analysis of the spoilage of wine. The potentiometric
278 electronic tongue was designed using thick-film serigraphic techniques and commercially available
279 pastes originally intended for resistances and conductors (i.e. Ag, Au, Cu, Ru, AgCl, and C). The
280 designed humid electronic nose contained a glass electrode, aluminium (Al), graphite and platinum
281 (Pt) wires and a Ag-AgCl reference electrode that were included in a damp fabric. The humid
282 electronic nose responds to volatile compounds that evaporate from the wine samples and that
283 dissolved and concentrated in the wet cloth where the potentiometric electrodes are included. The
284 process of wine spoilage when in contact with air was followed with the combined electronic system
285 with good results. Additionally, the spoilage was also assessed by using a simple determination of the
286 titratable (total) acidity. To check the system, three Spanish table wines, two red and one white, have
287 been analyzed. The wine bottles were all opened at the same time and measurements were made with
288 the wines for 48 days. A clear discrimination as a function of time was achieved.

289 **ACKNOWLEDGEMENTS**

290 We thank the Spanish Government (project MAT2009-14564-C04) the Generalitat Valenciana
291 (project PROMETEO/2009/016) for support. We would also like to thank the Universidad Politécnica
292 de Valencia for support (Primeros Proyectos de Investigación PAID-06-09).

293 REFERENCES

- 294 [1] R. S. Jackson. *Sensory Perception and Wine Assessment*. Wine Science. Third Edition (2008)
295 641-685
- 296 [2] J. Zeravik, A. Hlavacek, K. Lacina, P. Skládal. State of the Art in the Field of Electronic and
297 Bioelectronic Tongues – Towards the Analysis of Wines. *Electroanalysis* 21 (2009) 2509 – 2520
- 298 [3] J. Lozano, T. Arroyo, J. P. Santos, J.M. Cabellos, M.C. Horrillo. Electronic nose for wine ageing
299 detection. *Sens. Actuators, B* 133 (2008) 180–186
- 300 [4] C. Di Natale, F. A. M. Davide, A. D'Amico, P. Nelli, S. Groppelli, G. Sberveglieri. An electronic
301 nose for the recognition of the vineyard of a red wine. *Sens. Actuators, B* 33 (1996) 83-88
- 302 [5] M. Penza, G. Cassano. Chemometric characterization of Italian wines by thin-film multisensors
303 array and artificial neural networks. *Food Chem.* 86 (2004) 283–296
- 304 [6] M. García, M.J. Fernández, J.L. Fontecha, J. Lozano, J.P. Santos, M. Aleixandre, I. Sayago, J.
305 Gutiérrez, M.C. Horrillo. Differentiation of red wines using an electronic nose based on surface
306 acoustic wave devices. *Talanta*, 68 (2006) 1162-1165
- 307 [7] D. Cozzolino, H. E. Smyth, W. Cynkar, R. G. Damberg, M. Gishen. Usefulness of
308 chemometrics and mass spectrometry-based electronic nose to classify Australian white wines by
309 their varietal origin. *Talanta* 68 (2005) 382–387
- 310 [8] J. Lozano, J. P. Santos, T. Arroyo, M. Aznar, J. M. Cabellos, M. Gil, M. C. Horrillo. Correlating
311 e-nose responses to wine sensorial descriptors and gas chromatography–mass spectrometry
312 profiles using partial least squares regression analysis. *Sens. Actuators, B* 127 (2007) 267–276
- 313 [9] A. Guadarrama, J.A. Fernández, M. Íñiguez, J. A. de Saja. Array of conducting polymer sensors for
314 the characterization of wines. *Anal. Chim. Acta*, 411 (2000) 193-200.
- 315 [10] J. A. Ragazzo-Sanchez, P. Chalier, C. Ghommidh. Coupling gas chromatography and electronic
316 nose for dehydration and desalcoholization of alcoholized beverages. Application to off-flavour
317 detection in wine. *Sens. Actuators, B*, 104 (2004) 253-257.
- 318 [11] V. Parra, Álvaro A. Arrieta, José A. Fernández-Escudero, H. García, C. Apetrei, M. L.
319 Rodríguez-Méndez, J. A. de Saja. E-tongue based on a hybrid array of voltammetric sensors

- 320 based on phthalocyanines, perylene derivatives and conducting polymers: Discrimination
321 capability towards red wines elaborated with different varieties of grapes. *Sens. Actuators, B*, 115
322 (2006) 54–61
- 323 [12] A. Riul Jr., H. C. de Sousa, R. R. Malmegrim, D. S. dos Santos Jr., A. C. P. L. F. Carvalho, F. J.
324 Fonseca, O. N. Oliveira Jr., L. H. C. Mattoso. Wine classification by taste sensors made from
325 ultra-thin films and using neural networks. *Sens. Actuators, B*, 98 (2004) 77-82.
- 326 [13] L. Pigani, G. Foca, K. Ionescu, V. Martina, A. Ulrici, F. Terzi, M. Vignali, C. Zanardi, R. Seeber.
327 Amperometric sensors based on poly(3,4-ethylenedioxythiophene)-modified electrodes:
328 Discrimination of white wines. *Anal. Chim. Acta* 614 (2008) 213–222
- 329 [14] A. Legin, A. Rudnitskaya, L. Lvova, Yu. Vlasov, C. Di Natale, A. D’Amico. Evaluation of
330 Italian wine by the electronic tongue: recognition, quantitative analysis and correlation with
331 human sensory perception *Anal. Chim. Acta* 484 (2003) 33–44
- 332 [15] G. Verrelli, L. Francioso, R. Paolesse, P. Siciliano, C. Di Natale, A. D’Amico, A. Logrieco.
333 Development of silicon-based potentiometric sensors: Towards a miniaturized electronic tongue.
334 *Sens. Actuators, B*, 123 (2007) 191–197
- 335 [16] L. Rong, W. Ping, H. Wenlei. A novel method for wine analysis based on sensor fusion technique
336 *Sens. Actuators, B*, 66 (2000) 246-250
- 337 [17] S. Buratti, S. Benedetti, M. Scampicchio, E.C. Pangerod. Characterization and classification of
338 Italian Barbera wines by using an electronic nose and an amperometric electronic tongue. *Anal.*
339 *Chim. Acta*, 525 (2004) 133–139
- 340 [18] M.L Rodríguez-Méndez, A. Arrieta, V. Parra, A. Bernal, A. Vegas, S. Villanueva, R. Gutiérrez-
341 Osuna; Combination of an electronic nose, an electronic tongue and an electronic eye for the
342 Analysis of Red Wines aged with alternative methods. *IEEE Sensors Journal*, 4, (2004), 348-354
- 343 [19] R. H. Labrador, R. Masot, M. Alcañiz, D. Baigts, J. Soto, R. Martínez-Mañez, E. García-Breijo,
344 L. Gil, J.M. Barat. Prediction of NaCl, nitrate and nitrite contents in minced meat by using a
345 voltammetric electronic tongue and an impedimetric sensor *Food Chemistry* 122 (2010) 864–870
- 346 [20] R. Martinez-Mañez, J. Soto, E. Garcia-Breijo, L. Gil, J. Ibañez, E. Llobet, An “electronic tongue”
347 design for the qualitative analysis of natural waters. *Sens. Actuators, B*, 104 (2005) 302-307
- 348 [21] J. Soto, R. H. Labrador, M.D. Marcos, R. Martínez-Mañez, C. Coll, E. García-Breijo, L. Gil. A
349 model for the assessment of interfering processes in Faradic electrodes. *Sens. Actuators, A*, 142
350 (2008) 56-60

- 351 [22] R. Martínez-Máñez, J. Soto, E. García-Breijo, L. Gil, J. Ibáñez, E. Gadea. A multisensor in thick-
352 film technology for water quality control. *Sens. Actuators, A*, 120 (2005) 589-595
- 353 [23] L. Gil, J. M. Barat, E. Garcia-Breijo, J. Ibañez, R. Martínez-Máñez, J. Soto, E. Llobet, J.
354 Brezmes, M. C. Aristoy, F. Toldrá. Fish freshness analysis using metallic potentiometric
355 electrodes. *Sens. Actuators, B*, 131 (2008) 362–370
- 356 [24] V. Loureiro, M. Malfeito-Ferreira. Spoilage yeasts in the wine industry. *International Journal of*
357 *Food Microbiology*, 86 (2003) 23– 50
- 358 [25] A. González, N. Hierro, M. Poblet, A. Mas, J. M. Guillamón. Application of molecular methods
359 to demonstrate species and strain evolution of acetic acid bacteria population during wine
360 production. *International Journal of Food Microbiology*, 102 (2005) 295-304
- 361 [26] B.D. Ripley, *Pattern Recognition and Neural Networks*. Cambridge U.K: Cambridge Univer.
362 Press, 1996.
- 363 [27] R. Gutierrez-Osuna. Pattern Analysis for Machine Olfaction: A Review. *IEEE SENSORS*
364 *JOURNAL*, 2 (2002) 189-202
- 365
- 366

367 **VITAE**

368 *Luis Gil-Sánchez* was graduated in electronic engineering from the Universitat de Valencia (Spain) in
369 1998, and received his PhD in 2007 from the Universidad Politécnica de Valencia (UPV). He is
370 assistant professor of electronic technology in the Electronic Engineering Department at UPV. He is a
371 member of the Institute of Molecular Recognition and Technological Development (IDM). His main
372 areas of interest are the chemical sensors, instrumentation systems and pattern recognition for
373 electronic tongues.

374 *Juan Soto* was graduated in Chemistry from the Universitat de Valencia in 1981 and received his PhD
375 in 1986 in the same University. He is currently associate professor in the Department of Chemistry at
376 the Universidad Politécnica de Valencia. His main areas of interest are the development of chemical
377 chemosensors and probes, especially those based on electrochemical processes.

378 *Ramón Martínez-Mañez* was graduated in Chemistry from the Universitat de Valencia in 1986 and
379 received his PhD in 1990 in the same University. After a postdoctoral period at Cambridge (UK), he
380 joined the Department of Chemistry at the Universidad Politécnica de Valencia. He became full
381 professor in 2002. His main areas of interest are in the field of chromo-fluorogenic chemosensors and
382 molecular probes for anions, cations and neutral chemical species.

383 *Eduardo García Breijo* was graduated in electronic engineering from the Universitat de València
384 (Spain) in 1997, and received his PhD in 2004 from the Universidad Politécnica de Valencia (UPV).
385 He is an assistant professor of Electronic Technologic of UPV. He is a member of the Institute of
386 Molecular Recognition and Technological Development (IDM). His main areas of interest are the
387 development of multisensors in thick-film technology.

388 *Javier Ibáñez Civera* is Matrisse in Power Electronic and Control from the Universite Pierre et Marie
389 Curie (Paris VI) in 1994 and received his PhD in 2009 from the Universidad Politécnica de Valencia
390 (UPV). He is assistant professor of Electronic Technology in the Electronic Engineering Department
391 of the Universidad Politécnica de Valencia (UPV). He is a member of the Institute of Molecular
392 Recognition and Technological Development (IDM). His main areas of interest are water organic
393 contamination devices.

394 *Eduard Llobet* received the degree in telecommunication engineering and the Ph.D. degree from the
395 Universitat Politècnica de Catalunya, Barcelona, Spain, in 1991 and 1997, respectively. He is
396 currently an associate professor in the Electronic Engineering Department, Universitat Rovira i
397 Virgili, Tarragona, Spain. His main areas of interest are in the fabrication and modelling of

398 semiconductor chemical sensors and in the application of intelligent systems to complex odour
399 analysis.

Figure 1

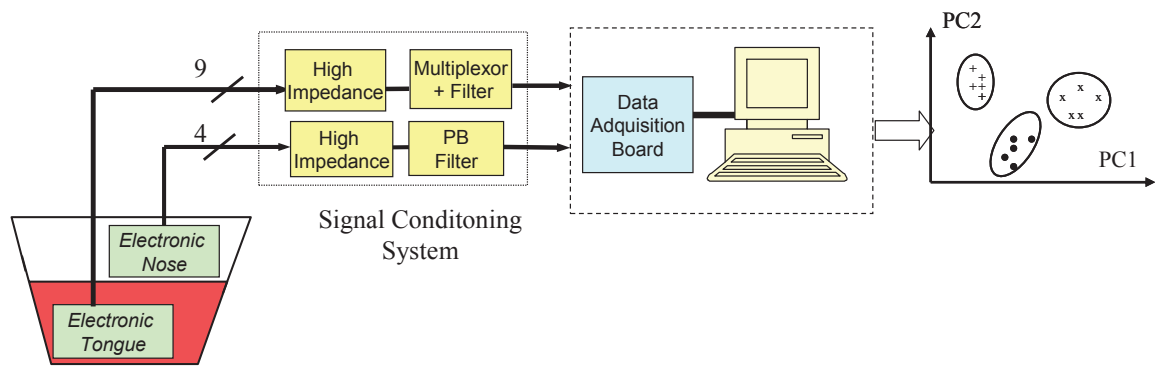

Fig. 1. Block diagram of the measurement system

Figure 2

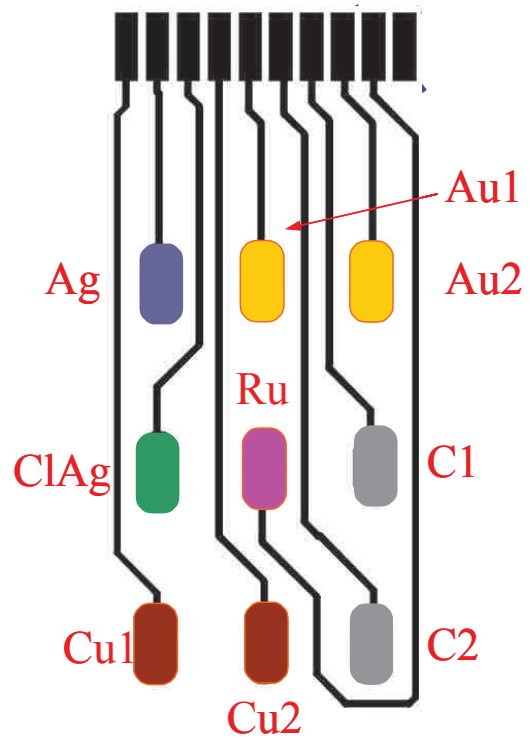

Fig. 2. Potentiometric sensors for electronic tongue

Figure 3

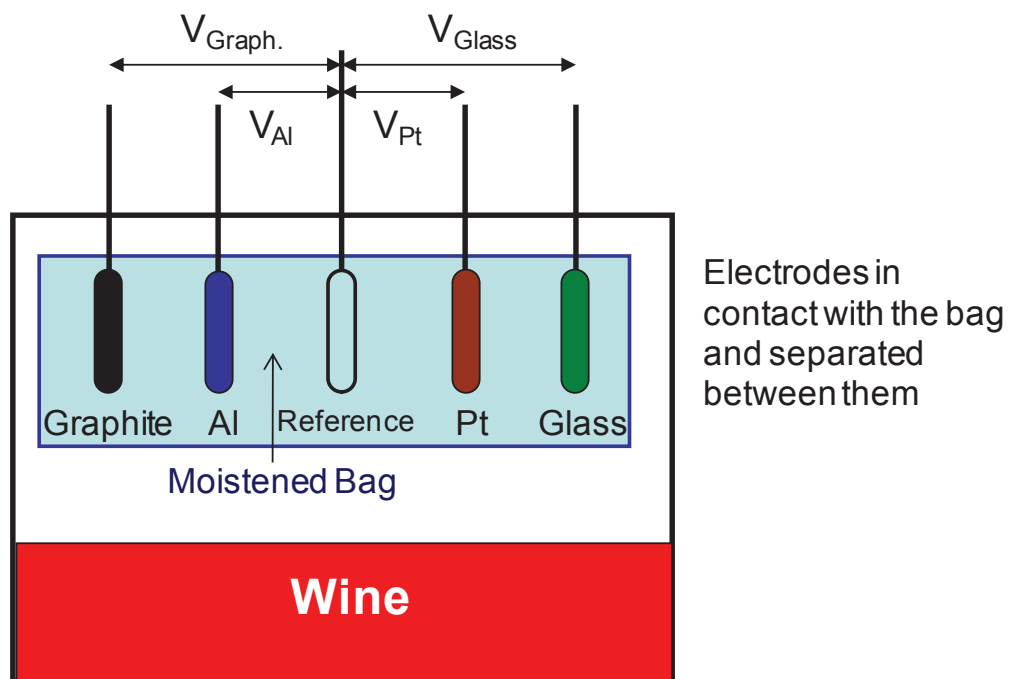

Fig. 3. Scheme of the humid electronic nose constructed using a set of electrodes closed in a piece of thin moistened cloth

Figure 4

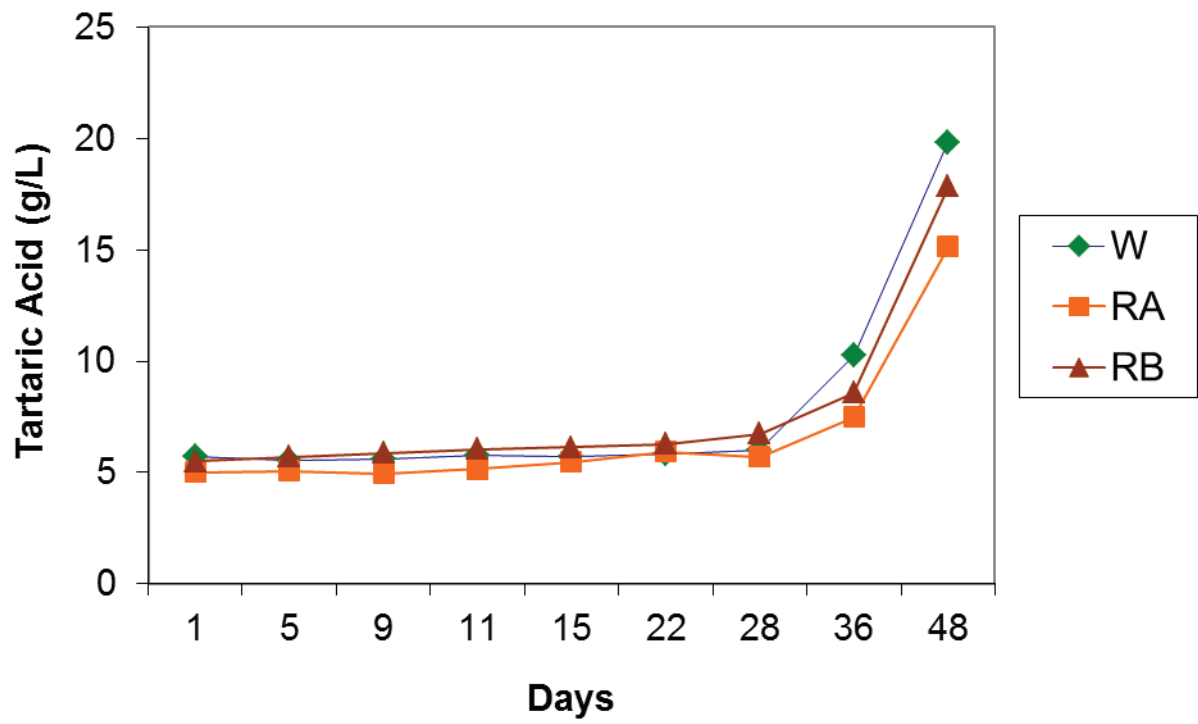

Fig. 4. Variation of acidity on two red wines (RA, RB) and a white wine (W)

Figure 5

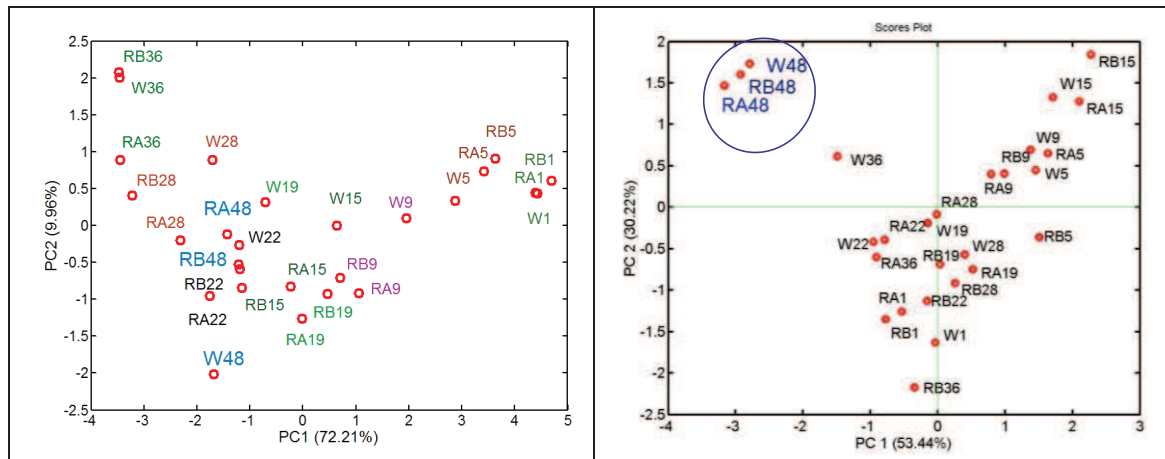

Fig. 5. PCA scores separately of the electronic tongue (left) and the electronic nose (right) on two red wines (RA, RB) and a white wine (W) using the experimental setup seen in Fig. 2 and Fig. 3. The number after RA, RB and W symbols represents the day the wines were measured after they were opened

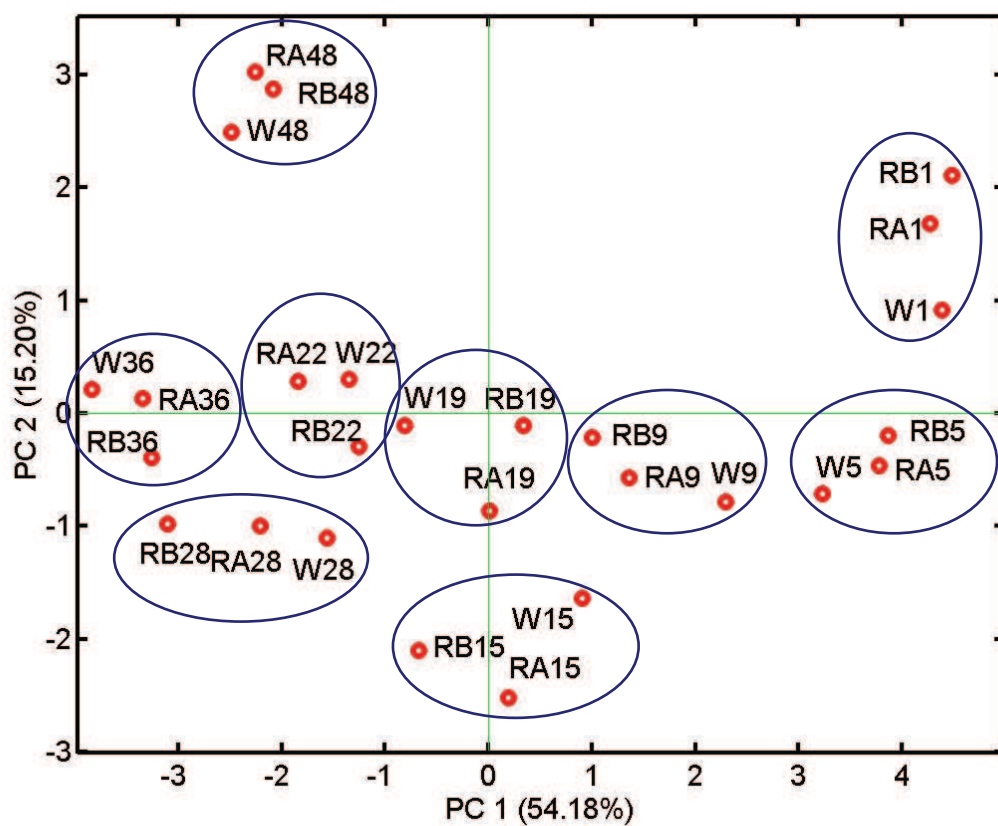

Fig. 6. Principal component analysis (PCA) score plot obtained by combination of measurements of the electronic tongue and the humid electronic nose on two red wines (RA, RB) and a white wine (W) using the experimental setup seen in Fig. 2 and Fig. 3. The number after RA, RB and W symbols represents the day the wines were measured after they were opened

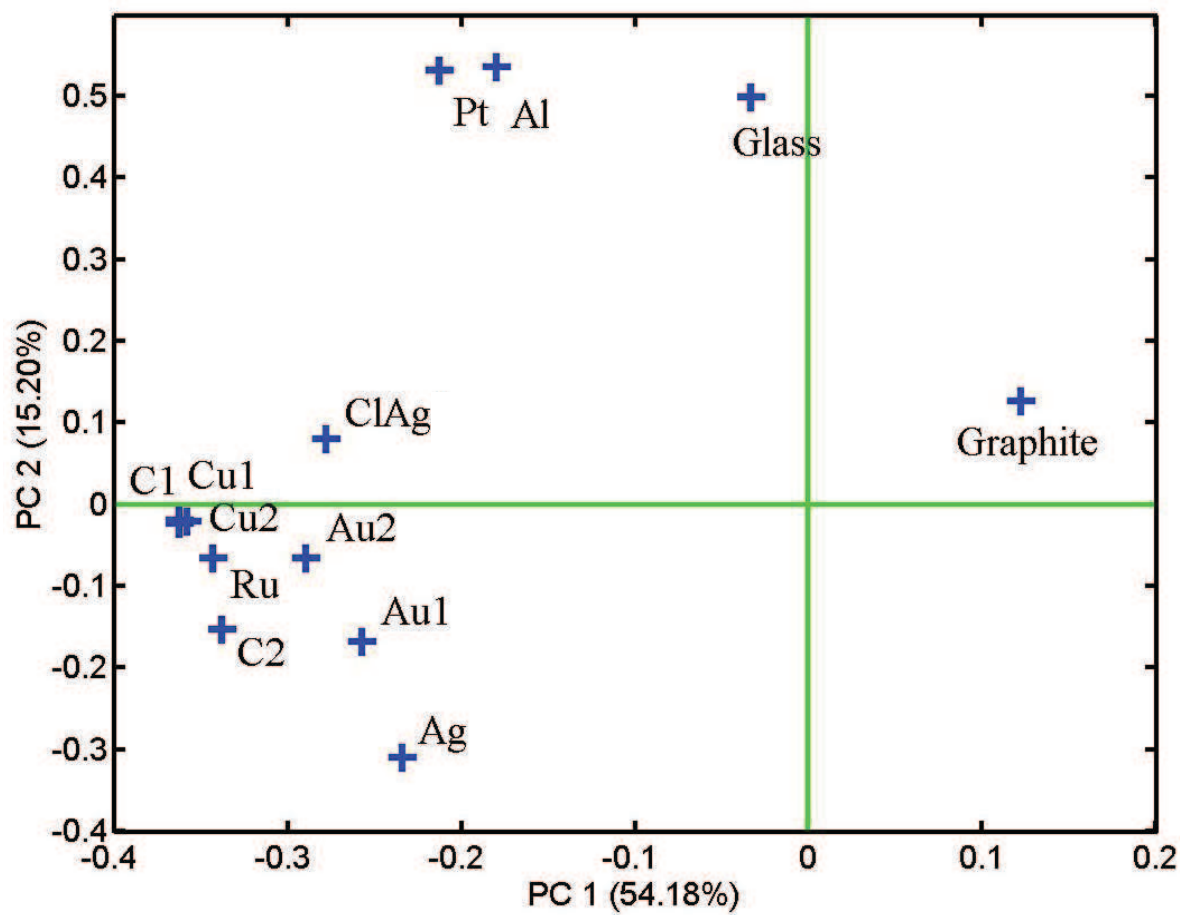

Fig. 7. PCA loads for data obtained by combination of measurements of the electronic tongue and the humid electronic nose on two red wines (RA, RB) and a white wine (W) using the experimental setup seen in Fig. 2 and Fig. 3. Symbols are related with the used electrodes; electronic tongue (see Figure 2): Ag, Au (two electrodes Au1 and Au2), Cu (two electrodes Cu1 and Cu2), Ru, AgCl, and C(graphite) (two electrodes C1 and C2); humid electronic nose (see Figure 3): C(graphite), Al, Pt and glass electrode

Figure 8

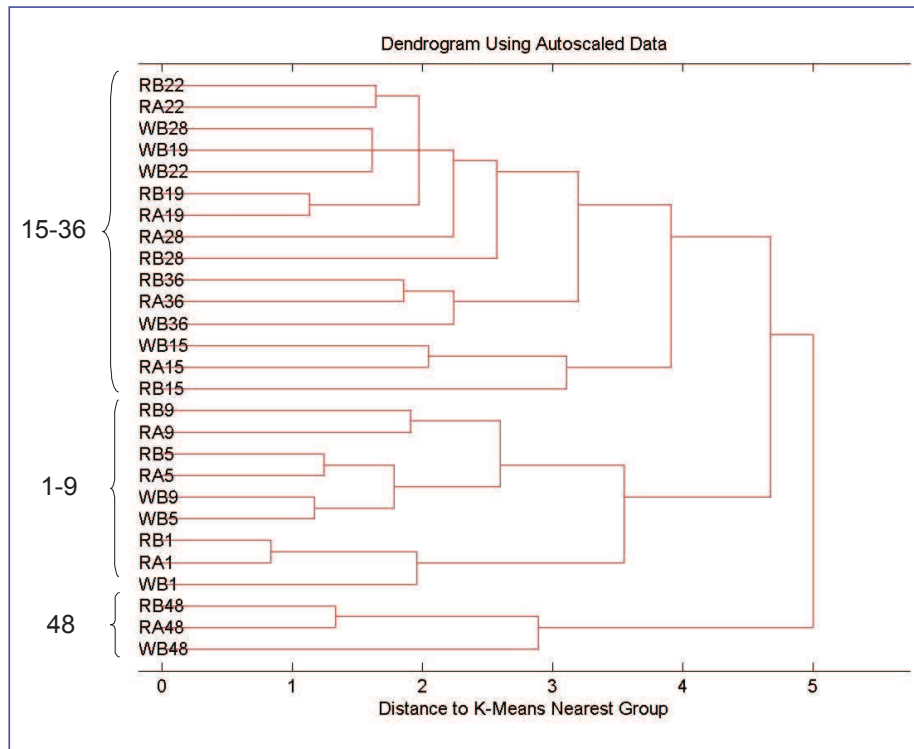

Fig. 8. Dendrogram using K-means on two red wines (RA, RB) and a white wine (W) using the experimental setup seen in Fig. 2 and Fig. 3. The number after RA, RB and W symbols represents the day the wines were measured after they were opened